

INSTRUCTIONS No. 2407C

FOR SETTING UP AND OPERATING

Fairbanks-Morse

1½ H. P. Type "Z"

Hit and Miss Gasoline Engine

This book should be carefully read before attempting to do anything with the engine.

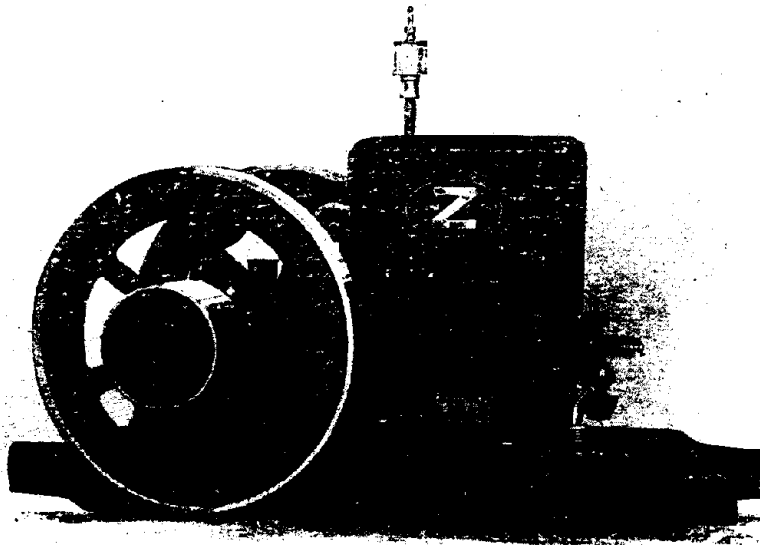

Fig. 3310

Reprinted by Jean Metcalf Ashtabula, Ohio

FAIRBANKS, MORSE & CO.
(INCORPORATED)

(Copyright, 1917, by Fairbanks, Morse & Co.)

INSTRUCTIONS No. 2407C

**For Setting Up and Operating Fairbanks-Morse
1½ H. P. Type "Z" Hit and Miss Gasoline Engine.**

Remove engine from crate, being very careful to avoid damage.

**When Engine
is Received
Location**

If engine is permanently located, leave two or three feet of room all around. Bolt down to a plank on a foundation.

If in a building, the exhaust pipe may be carried outside. This should be short and with few bends. Water may collect in long exhaust pipes so a small hole or other drain should be provided at the lowest place.

**If Located in
a Building.**

Read the tags on the engine but do not remove them until you are familiar with its operation.

Read Tags.

These engines use Gasoline, or other equally volatile fuels.

Fuel.

WHAT TO DO BEFORE STARTING.

1. Fill fuel tank with gasoline.
2. Fill water hopper three fourths full. Hot water helps starting in cold weather.
3. Fill oil cup (527, page 8) on cylinder and adjust to feed 6 drops per minute. Use "Hytest" oil or other equally good. Fill the three grease cups. Two (505, page 9) are on main bearing. These should be screwed down one or two turns until grease is surely forced into bearings. The third (509, page 8) is on the crank pin bearing. This has a spring plunger that is drawn up to the top by a wing nut on a screw. After filling this cup the wing nut must be screwed back to bring the spring plunger against the grease so that it will feed out gradually.

**Fill Fuel Tank.
Cooling Water
Oil.**

With a hand oil can go over the engine and oil the governor and all other places where there are oil holes, and wherever one part moves against another. Notice particularly the oil hole in the hub of the cam gear (28, page 9).

4. Open throttle valve (76, page 8) about one turn.

Fuel Valve

TO START ENGINE.

5. Apply the starter crank and spin the engine at the same time, holding the suction or upper valve open with the left hand. After getting the engine in motion, release the suction valve and half close the air inlet opening in bottom of reservoir with fingers of left hand **for one revolution only**, and then remove fingers while still continuing to crank. If held longer too much fuel will be drawn in. The mixture will not explode if there is too much fuel in it. If the engine is flooded, the surplus must be worked out by cranking.

Starting

AFTER ENGINE IS STARTED.

6. After engine takes its first explosion, remove the starter crank and set throttle back to running position. This position in final test was with the mark straight down. The best position varies slightly with the fuel used and also with the temperature and should be set to feed the least quantity of gasoline, engine will run well on.

**Remove
Starter Crank
and Set Fuel
Throttle.**

TO STOP ENGINE.

7. To stop engine, close throttle, close cylinder oiler and in freezing weather, drain out the water.

DESCRIPTION OF PARTS OF ENGINE AND MANNER OF ADJUSTMENT.

Suction Feed. 8. Gasoline is lifted from the tank into the cylinder by suction. If the engine should miss fire or back fire in the suction elbow, or show lack of power with plenty of gasoline in the tank, examine the check valve (A) Chart 1716GN, page 5. This is supplied with a fine wire screen in the lower end which may be clogged. If engine will only run by partly closing the air inlet, this indicates some trouble with this check valve.

Igniter. 9. The fixed electrode (137 page 8) is held between mica washers (257, page 8) on each end. A nut clamps this electrode firmly in position. This nut must be tight to prevent the electrode from turning.

The spark can be seen on this engine if suction elbow is removed when the engine is turned fast with starter crank.

Replacing Points. If, by continued use, the points become worn and a good spark cannot be obtained, the electrode points in the fixed and movable electrodes can be removed by filing off the end and driving out and replacing with new ones.

Adjusting Electrodes. 10. Should it ever become necessary to replace the movable electrode or moving parts, the igniter should be adjusted as follows:

Time of Contact. Assemble the movable electrode in the igniter with the electrode pawl, collar and spring. Place pawl (134, page 8) against the stop pin (305, page 8) and adjust movable electrode to have 1-16" between electrode points. Then tighten clamp screw taking care not to have over 1/64" end play in movable electrode, and be sure and draw clamp screw very tight. If this clamp piece slips engine will not run.

Igniter Setting. 11. The igniter is set to "snap" or spark when the crank is 20° to 25° before the inner dead center, coming up. The "spark" mark on the face of the flywheel is then passing the exhaust rod. Note, also, the magneto timing as per paragraph No. 15.

Cleaning Igniter. 12. If explosions are missed after engine has run well igniter may need cleaning. Take it out and if covered with dirt clean this off. The insulated electrode may

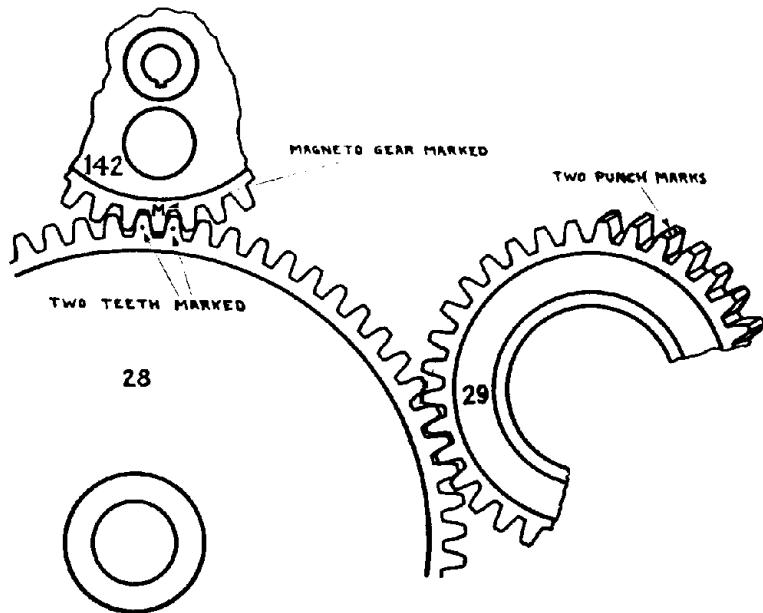

CHART 1814GN

also be removed from igniter and all parts cleaned using alcohol or gasoline. In replacing be sure and have points come squarely together. This better not be taken out unless trouble has been traced to this point.

SETTING GEARS.

13. The magneto gear (142, pages 2 and 8) has the letter "M" stamped on the edge of one tooth. The two teeth on the largest gear (28, pages 2 and 8), between which this marked tooth should mesh, are each marked with a single punch mark on the edge of the tooth, as shown on chart 1814GN (page 2). Gears are also marked with two center punch marks on face of tooth. The pinion (29, pages 2 and 8) on crank shaft has one tooth with two center punch marks. This tooth should come between the two marked ones on the largest gear.

Gear Markings.

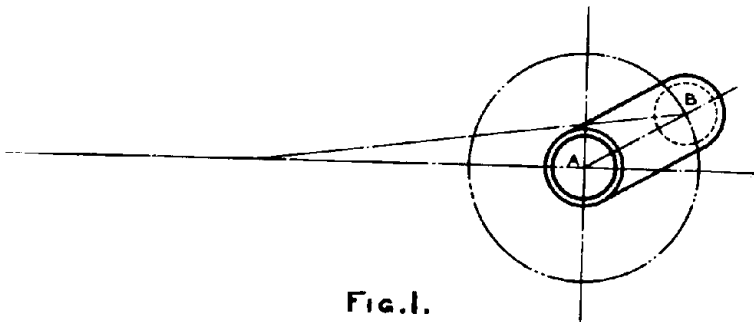

Fig. 1.

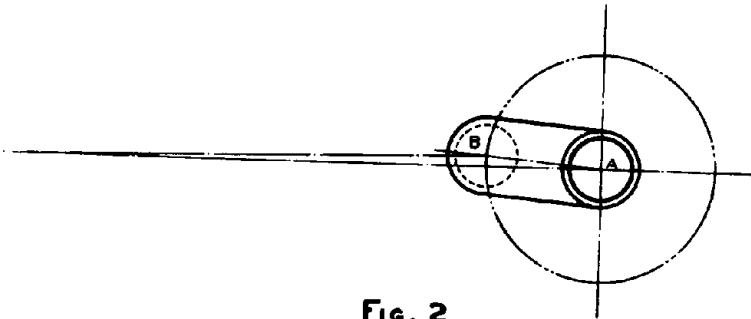

Fig. 2.

CHART 267ND1

14. If engine is taken apart and the marks on Chart 1814GN cannot be found, or if old gear is replaced by a new one, the cam gear should be set as follows:

Place the crank (25, page 8) in a vertical position and pointing up. Then set the cam gear with the nose of the cam straight up. This should bring the valve timing very nearly as shown in Figs. 1 and 2, Chart 267ND1.

Valve Setting.

The cam should begin to open the exhaust valve 30° to 35° before outer dead center, and should close the exhaust valve when the crank AB is in the position shown by Figure 2 of the cut, or about 5° above the inner dead center. The valve can be turned with the fingers the instant it is lifted from its seat.

INSTRUCTIONS FOR TIMING AND CARE OF SUMTER BUILT-IN MAGNETO.

Properly
Timed at
Factory.

15. The engine leaves the factory with built-in magnetos which are properly timed and wired.

Magneto
Gear
Marked.

The magneto gear (142, pages 2 and 8) and its driving gear (28, pages 2 and 8) are marked so that in case the magneto is removed from engine for any reason it can easily be retimed. See paragraph 13.

Where Cam
Gear is not
Marked.

In case the cam gear is broken, the gear sent for repairs will not be marked and it will therefore be necessary, after setting exhaust cam to time the magneto by using the timing mark on the armature shaft. To get the correct timing for the magneto with reference to the engine proceed as follows:

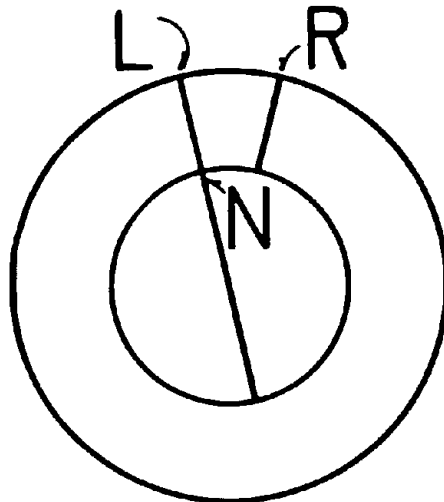

CHART 1526GN3
Diagram of End of Magneto Shaft and Bearing

Timing
Magneto.

Turn the engine over in the direction it runs until igniter snaps (see paragraph 11), and then set magneto so that timing mark N is in line with mark L or slightly past the mark. The magneto is then properly timed.

Note.—The marks (illustrated by letters N, L, and R) on Chart 1526GN3, are on the end of the magneto shaft and bearing.

Oiling
Magneto.

See that the magneto bearings are oiled only a little but regularly. (Do not use heavy cylinder oil.) Do not flood the magneto with oil. Use a fine wire to drop oil on its bearings. One drop of oil or two, on each bearing each day is enough.

Do Not Take
Magneto
Apart.

The magneto **must not be taken apart**. If it is manufacturers will not be responsible for its further operation.

Do Not Alter
Wiring.

Do not attempt to alter the wiring on engine.

Locating
Ignition
Trouble.

16. Try to definitely locate the part in which the trouble occurs. (A) Possibly the wire is defective, try an outside wire. (B) Take off magneto, see that the marks are as shown on Chart 1526GN3, turn armature quickly so that the marks pass one another. At this time scrape end of wire over screw on side; if a good spark is obtained, the trouble is not in the magneto. This can also be determined by wetting the thumb

and finger and putting across from terminal to any bright screw; if a slight shock is felt the magneto is probably all right. (C) If both of above points are correct, see that the time of contact is right (see page 11). (D) The Igniter may be short circuited (see paragraph 12).

Carefully examine the wire and see that there are no bare spots touching any part of the engine, especially the hot cylinder. The insulation on the wire may in time become defective, when new wire should be put on.

Test Wiring.

The magneto will be ruined if a battery wire is attached to the igniter insulated terminal without first disconnecting the magneto wire or if any electric current is passed through the magneto.

Special Caution.

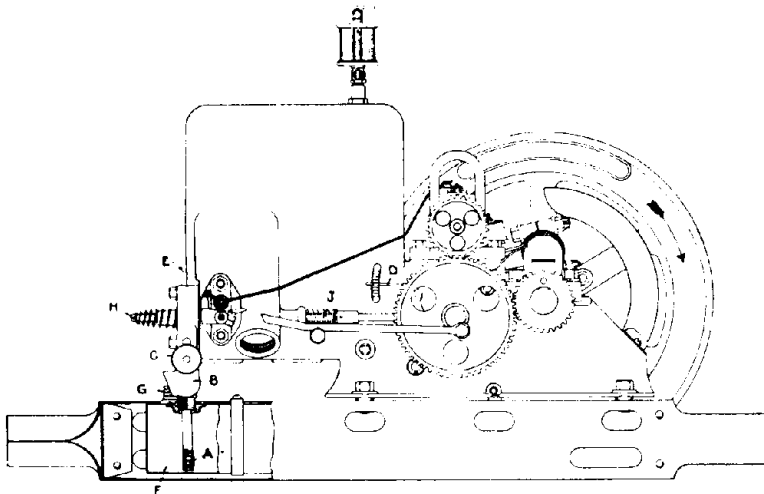

7604
7604

CHART 1716GN

17. While operating engine the evaporator tank should not be filled more than three-fourths full of water, otherwise water will splash out more or less after it becomes boiling hot. The water should never be allowed to fall as low as the top of the cylinder wall, as the cylinder will then get too hot. It is to be expected that the water will boil, but the engine will work properly when the water is boiling. Replenish the water as it evaporates.

Temperature of Cooling Water.

The engine jacket is liable to be broken by freezing if water is left in during cold weather, unless non-freezing solution is used.

Engine Jacket Broken by Freezing.

A non-freezing mixture of calcium chloride and water may be used in the jacket. Three pounds of calcium chloride to each gallon of water will not freeze solid at zero Fahrenheit. It is advisable, however, to drain the jacket in freezing weather when the engine is not in use.

Non-Freezing Solution.

18. Each engine is regularly equipped with steel skids (73, page 9) containing a galvanized steel fuel tank (15, page 8), which is sent out piped up complete. The filler

Fuel Supply.

Instructions—Fairbanks-Morse Type "Z" Gasoline Engines

opening in tank is on side of engine opposite governor. In filling use the tin funnel supplied with engine. Replace cap after filling to prevent water and foreign matter entering and keep small vent hole in cap open. Water will separate from fuel oils and remain at the bottom. It can be most conveniently removed with a syphon made out of any small tubing discharging into a basin setting on the floor. If rubber tubing is used it should be washed out after using as fuel oil injures rubber if left in contact long. The syphon is made by bending the tube into a U shape with one end long enough to extend to the bottom of the fuel tank, inserted through the filling hole, and the other extending down to the floor or even with the bottom of the engine base. To start the syphon fill it full of liquid, either water or fuel, then while holding a finger over the discharge end, insert the other end into the fuel tank but do not remove the finger until the inner end is in the liquid in the tank and the outer end in the receiving vessel and below the level of the liquid in the tank.

Drain
Fuel Tank

DESCRIPTION AND DIRECTIONS FOR CLEANING, ADJUSTING AND CARE OF PARTS OF THE ENGINE.

Inlet Valve

19. This is a poppet valve, automatic in action, and lifts against a spring on the valve stem.

Cost
Compressor

Should the engine at any time on starting turn too easily, or have lost its compression, it is evident that a leak is taking place and both valves should be examined; they may not seat tightly.

Cleaning and
Regrinding
Inlet Valve

20. To clean or regrind the inlet valve H, (page 5) remove suction elbow as described above, then remove cotter through valve stem, which holds spring, when valve can be withdrawn from elbow for cleaning. To grind valve use a mixture of ground glass or fine emery and oil, spread evenly on valve, and rotate same with a screw driver a few times in alternate directions, lifting it clear from its seat frequently to allow the abrasive to distribute itself evenly on the seat.

After grinding, clean both valve and seat with gasoline before replacing.

Cleaning and
Regrinding
Exhaust
Valve

21. This valve J, (page 5) is constructed the same as the inlet valve, excepting that it is operated by a push rod and cam. To remove this valve for cleaning or regrinding, it is first necessary to remove suction elbow as described above, then remove cotter through exhaust valve collar, when valve can be withdrawn through suction elbow opening. To clean or regrind this valve, proceed same as for inlet valve described above, being sure to clean valve and seat with gasoline before replacing.

Suction
Elbow

Explosive
Mixture

22. The suction action of the piston draws air through air inlet opening in suction elbow B (Chart 1716GN, page 5). By the swift velocity of this in-going air, sufficient fuel is picked up and drawn through a small nozzle which extends into the passage to form an explosive mixture, which is then drawn into the cylinder. The asbestos gasket under this elbow will hold better if coated with linseed or lubricating oil. After putting on a new gasket the nuts should be tightened finally when engine is hot.

Action of
Governor

23. The governor in the flywheel controls the exhaust valve through the action of the detent catch. The clearance between the detent catch and the detent blade should not exceed $1/32$ " when the blade swings in and the rocker catch is held out by the action of the exhaust cam. To try this, hold the governor weight out against its stop and turn the engine flywheel over by hand until the exhaust valve opens wide. This brings the detent into engagement with the rocker catch plate and holds it when the rocker returns.

Detent
Blade
Clearance

If the clearance between the blade and catch plate is too small, the detent blade will strike the plate before the valve is open fully and the engine will not govern. This should be corrected by bending the tail of the detent out very slightly.

If the detent is forced into engagement and then swings out again before the exhaust valve starts to close, it shows that the detent tail is bent out too far and engine would run away. This should be corrected by bending the detent tail in slightly so that the blade will stay in and lock with the rocker catch plate when the valve starts to close.

If a governor weight or detent is installed for repairs the above clearance should be maintained. This is important for proper action of the governing parts.

**Governor
Repair
Parts.**

24. Normal speed of engine is 500 R. P. M., and is maintained by the proper tension of the governor spring; tightening this increases and loosening decreases the speed.

**Speed of
Engine.**

25. The throttle valve C (Chart 1716GN, page 5) is to shut off the supply of fuel and to regulate by set point the proper quantity to be fed to engine.

**Throttle
Valve.**

26. The speed of the engine can be decreased by lowering the speed regulator lever D (Chart 1716GN, page 5) held by notches on side of cylinder.

**Decreasing
Engine
Speed.**

27. Occasionally it may become necessary to remove the piston for the purpose of cleaning the rings. To remove the piston, take off oil shield and remove cotters and castle nuts from connecting rod bolts. Now remove connecting rod cap (20, page 8) and turn crank shaft so that crank pin is in extreme out position. The piston may now be withdrawn. Care must be taken to replace piston in its original position. Care must also be taken to replace all parts in the reverse order from which they were removed and in the same position and to spread all cotters.

**To Remove
The Piston.**

28. The piston should be cleaned with kerosene oil, the rings loosened up and the grooves cleaned. Oil piston well before replacing. The rings can be removed by taking three strips of tin one-half inch wide and six inches long, slipping one under each end of a ring, then taking the third strip and slipping it under the middle of the ring the ring can then be slipped out of the groove and off the piston and both ring and grooves cleaned. Replace in the same manner.

**To Remove
Rings.**

Repair Chart for 1½ H. P. Type "Z" Gasoline Engine

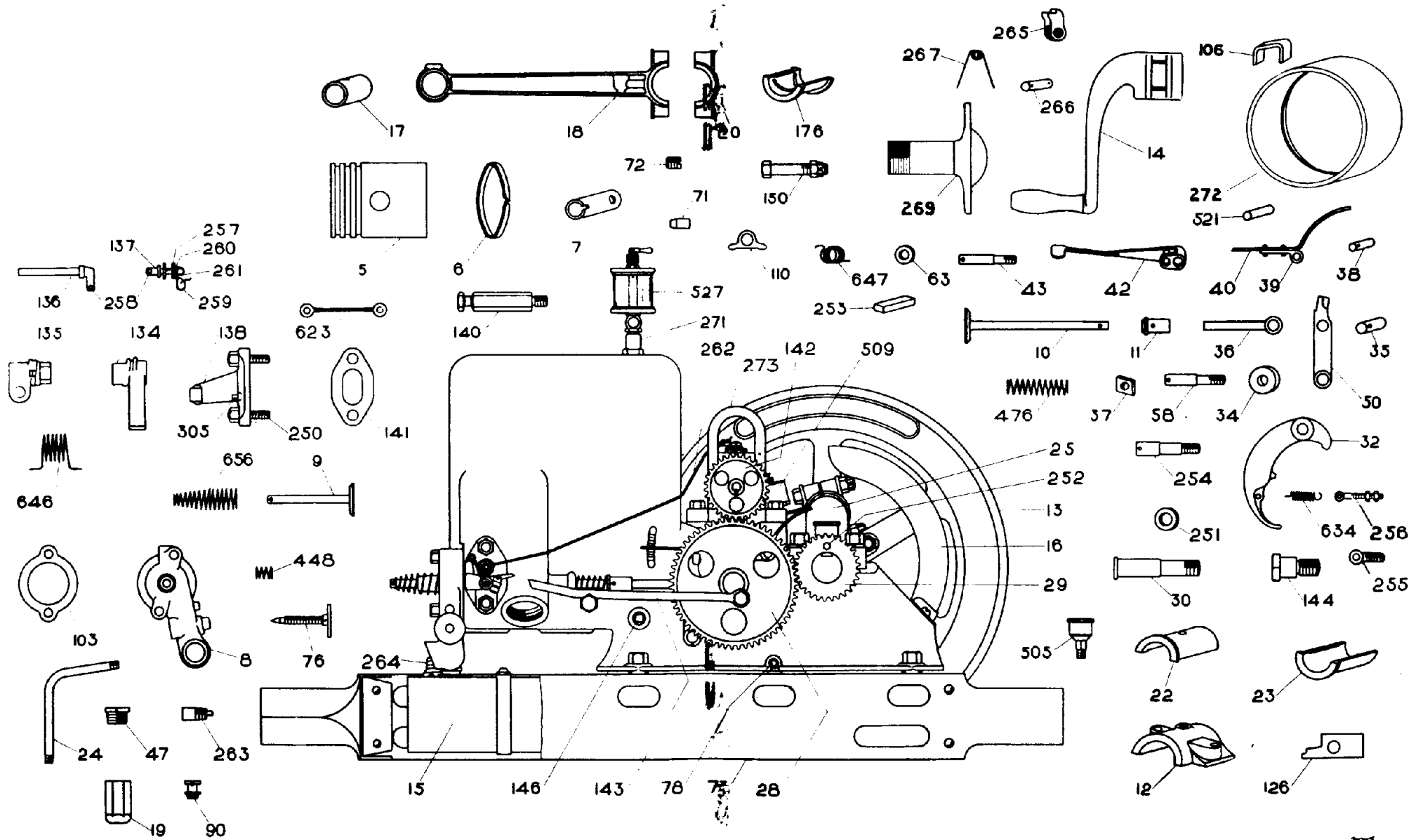

REPAIR PARTS LIST

For Fairbanks-Morse 1½ H. P. Hit-and-Miss Governor Type "Z" Gasoline Engine.

When ordering parts for repairs, give the description as given in this list, both by repair number and name of parts wanted; also the horse-power, type and shop number of the engine, which will be found stamped on the pad on top of the evaporator cylinder. Too much care cannot be taken in giving these particulars.

The first column at the left of each page shows the repair numbers of all complete groups and all separate parts, arranged in numerical order.

The second column at left of page, between any two horizontal lines, shows the repair numbers of parts included in that group.

Unless repair numbers (between any two horizontal lines), do appear in the second column at left of page, they do not constitute a group.

The group number, when shown in heavy type, followed by the letter "C" (indicating complete), at the head of a group of parts in list, covers all items mentioned in that group.

To determine repair numbers and names of parts wanted, and whether they can be ordered by group number, find on accompanying repair chart the repair numbers of parts wanted, and by referring to these repair numbers in the first column at left of page, determine the names of parts and whether they make up a complete group, or should be ordered separately. Always order by group number if possible, but before doing so, carefully check over such group, to make sure that all parts included therein are wanted, as they will all be furnished unless otherwise specified.

If, in ordering repairs, it is found that in any group consisting of several parts, everything except one or two items is wanted, instead of ordering separately the balance of parts wanted in this group, order by group number and specify "less" the repair symbols of parts not wanted. For example: If in the 8-C group, Nos. 76 and 448 are not wanted, order should read: "8-C less Nos. 76 and 448"

If any unsymbolized parts are wanted, such as Bolts, Screws, etc., find on chart the repair number of part on which they are used and then, by referring to list, the bolts, etc., will be found directly after the numbered part with which they are used. The name of part, as given in this list, should always be used in ordering all unsymbolized parts.

Repair Numbers Arranged Numerically.	The repair number in heavy type, when shown at the head of a group of parts, includes all items mentioned in that group.	Included in Group	No. Used
1-C	1-C Cylinder and Base.		1
1	1 Cylinder and Base, always fitted with:		
	78 Cylinder Drain Plug.....		
	146 Base Drain Plug.....		
	250 Cylinder to Igniter Studs (2).....		
	521 Detent Stop Pin.....		
	12 Main Bearing Caps (2).....		1
	Main Bearing Cap Cap Screws (4).....		
	Main Bearing Cap Cap Screw Lock Washers (4).....		
	126 Main Bearing Cap Shims (Set of eight).....		
	195 Name Plate.....		
	Name Plate Brass Machine Screws (2).....		
	Name Plate Rubber Washers (2).....		
	22 Main Bearing Upper Liners.....		2
	23 Main Bearing Lower Liners.....		2
5-C	5-C Piston.		1
5	5 Piston, always fitted with:		
	Piston Ring Stop Pins (Three). (Not furnished separately).....		3
6	6 Piston Rings.....		3
7	7 Piston Pin.....		1
	71 Piston Pin Lock Pin.....		1
	72 Piston Pin Lock Pin Screw.....		1
	Piston Pin Lock Pin Lock Washer.....		1
8-C	8-C Suction Elbow.		1
8	8 Suction Elbow, always fitted with:		
	263 Suction Elbow Nozzle (not furnished separately).....		1
9	9 Suction Valve with Cotter.....		1
	666 Suction Valve Spring.....		1
	76 Suction Elbow Needle Valve.....		1
	448 Suction Elbow Needle Valve Spring.....		1

Repair Parts List—Fairbanks-Morse Type "Z" Gasoline Engine

11
2407C

Repair Numbers Arranged Numerically.	The repair number in heavy type, when shown at the head of a group of parts, includes all items mentioned in that group.	Included in Group Number	No. Used
	Suction Elbow to Cylinder Cap Screws.....		2
	10-C Exhaust Valve.		
10-C			1
10	10 Exhaust Valve, with Cotter.....		1
11	11 Exhaust Valve Spring Collar.....		1
	476 Exhaust Valve Spring.....		1
12	Main Bearing Caps.....	1-C	2
	Main Bearing Cap Cap Screws.....	1-C	4
	Main Bearing Cap Cap Screw Lock Washers.....	1-C	4
13	13 Flywheel (Opposite Governor Side), always fitted with: Flywheel Clamp Bolt, with Nut.....		1
13A	13A Flywheel (Governor Side), always fitted with: 252 Crankshaft Pinion Pin.....		1
	Flywheel Clamp Bolt, with Nut.....	13 or 13A	2
	14-C Starter Crank.		
14-C			1
14	14 Starter Crank.....		1
	265 Starter Crank Pawl.....		1
	267 Starter Crank Pawl Spring.....		1
	266 Starter Crank Pawl Pin, with Cotters.....		1
15	15 Fuel Tank, always fitted with: 264 Fuel Tank Screw Cap.....		1
16	Fuel Tank to Skid Machine Screws, with Nuts.....		4
	Oil Shield.....		1
	Oil Shield to Base Machine Screws.....		2
17	Connecting Rod Piston Pin Bushing.....	18-C	1
	18-C Connecting Rod.		
18-C			1
18	18 Connecting Rod, always fitted with: 7 Connecting Rod Piston Pin Bushing.....		1
	20 Connecting Rod Piston Pin Bushing Dowel.....		1
	110 Connecting Rod Cap.....		1
	150 Connecting Rod Shim (Set of four).....		1 set
	151 Connecting Rod Bolts, with Cotters only.....		2
	151 Connecting Rod Bolt Castle Nuts.....		2
	176 Connecting Rod Crank Pin Bushings (Halves).....		2
	19-C Fuel Check Valve Seat with Valve.		
19-C			1
19	19 Fuel Check Valve Seat with Wire Gauze in end.....		1
	99 Fuel Check Valve.....		1
20	Connecting Rod Cap.....	18-C	1
22	Main Bearing Upper Liners.....	1-C	2
23	Main Bearing Lower Liners.....	1-C	2
	24-C Fuel Suction Pipe.		
24-C			1
24	24 Fuel Suction Pipe.....		1
	47 Fuel Suction Pipe Bushing.....		1
	19-C Fuel Check Valve Seat—Complete.....		1
25	Crankshaft.....		1
	28-C Cam Gear.		
28-C			1
28	28 Cam Gear.....		1
	144 Igniter Rod Pin.....		1
29	Crankshaft Pinion.....		1
	30-C Cam Gear Fulcrum Pin.		
30-C			1
30	30 Cam Gear Fulcrum Pin.....		1
	Cam Gear Fulcrum Pin Nut.....		1
	32-C Governor Weight.		
32-C			1
32	32 Governor Weight.....		1
	634 Governor Weight Spring.....		1
	256 Governor Weight Spring Eyebolt with Nuts. (Thru 235 Eyescrew).....		1
	254 Governor Weight Fulcrum Pin with Cotter.....		1
	251 Governor Weight Fulcrum Pin Washer.....		1
	251 Governor Weight Fulcrum Pin Nut.....		1
	255 Governor Weight Eyebolt Eyescrew. (In Flywheel Arm).....		1

Repair Parts List—Fairbanks-Morse Type "Z" Gasoline Engine

Repair Numbers Arranged Numerically.	The repair number in heavy type, when shown at the head of a group of parts, includes all items mentioned in that group.	Included in Group Number	No. Used
34	Exhaust Rocker Roller.....	50-C	1
35	Exhaust Rocker Roller Pin with Cotter.....	50-C	1
36	Exhaust Valve Push Rod.....	50-C	1
37	Detent Catch Plate.....	50-C	1
	Detent Catch Plate Cap Screw.....	50-C	1
	Detent Catch Plate Cap Screw Lock Washer.....	50-C	1
38	Detent Fulcrum Pin with Cotter.....	42-C	1
36	39 Detent Fulcrum, always fitted with:	42-C	1
40	40 Detent Blade—riveted on. (Not furnished separately.).....		
42-C Detent Carrier and Speed Regulator Handle.			
42-C	42 Detent Carrier and Speed Regulator Handle.....		1
42	43 Detent Carrier and Speed Regulator Handle Fulcrum Pin fitted with:		1
43	43 Detent Carrier and Speed Regulator Handle Fulcrum Pin Washer.....		1
	43 Detent Carrier and Speed Regulator Handle Fulcrum Pin Cotter.....		1
	43 Detent Carrier and Speed Regulator Handle Fulcrum Pin Nut.....		1
	39 Detent Fulcrum with:		1
	40 Detent Blade (riveted on.).....		1
	38 Detent Fulcrum Pin with Cotter.....		1
	647 Spring.....		1
47	Fuel Suction Pipe Bushing.....	24-C	1
50-C Exhaust Rocker.			
50-C	50 Exhaust Rocker.....		1
50	58-C Exhaust Rocker Fulcrum Pin—Complete.....		1
	34 Exhaust Rocker Roller.....		1
	35 Exhaust Rocker Roller Pin with Cotter.....		1
	36 Exhaust Valve Push Rod.....		1
	37 Detent Catch Plate.....		1
	Detent Catch Plate Cap Screw.....		1
	Detent Catch Plate Cap Screw Lock Washer.....		1
55-C Exhaust Rocker Fulcrum Pin.			
55-C	58 Exhaust Rocker Fulcrum Pin, with Cotter.....		1
58	Exhaust Rocker Fulcrum Pin Nut.....		1
	251 Exhaust Rocker Fulcrum Pin Washer.....		1
63	Detent Carrier and Speed Regulator Handle Fulcrum Pin Washer.....	42-C	1
71	Piston Pin Lock Pin.....	5-C	1
	Piston Pin Lock Pin Lock Washer.....	5-C	1
	Piston Pin Lock Pin Screw.....	5-C	1
72	Engine Skids.....		4
73	Engine to Skid Machine Bolts.....		1
76	Suction Elbow Needle Valve, with Handle.....	8-C	1
78	Engine Base Drain Plug.....	1-C	1
90	Fuel Check Valve.....	19-C	1
103	Suction Elbow to Cylinder Gasket.....		3
106	Pulley Clip.....		1
110	Connecting Rod Shims (Set of four).....	18-C	1 set
126	Main Bearing Cap Shims (Set of eight).....	1-C	1 set
130	Magneto to Igniter Wire.....		1
131	Igniter Fixed Electrode Nut.....	138-C	1
134	Igniter Movable Electrode Pawl.....	138-C	1
135	Igniter Movable Electrode Collar.....	138-C	1
	Igniter Movable Electrode Collar Clamp Screw.....	138-C	1
136	136 Igniter Movable Electrode, always fitted with:	138-C	1
	258 Igniter Movable Electrode Contact Point.....		
137	137 Igniter Fixed Electrode, always fitted with:	138-C	1
	258 Igniter Fixed Electrode Contact Point.....		
138-C Igniter.			
138-C	138 Igniter Body, always fitted with:		1
138	305 Igniter Movable Electrode Pawl Stop Pin.....		1
	136 Igniter Movable Electrode, always fitted with:		1
	258 Igniter Movable Electrode Contact Point.....		1
	134 Igniter Movable Electrode Pawl.....		1
	646 Igniter Movable Electrode Pawl Spring.....		1
	135 Igniter Movable Electrode Collar.....		1
	Igniter Movable Electrode Collar Clamp Screw.....		1
	623 Igniter Movable Electrode to Body Wire Connector.....		1
	Igniter Movable Electrode to Body Wire Connector Machine Screws.....		2
	Igniter Movable Electrode to Body Wire Connector Machine Screw Lock Washers.....		2
	137 Igniter Fixed Electrode, always fitted with:		1
	258 Igniter Fixed Electrode Contact Point.....		2
	257 Igniter Fixed Electrode Mica Washers.....		1
	259 Igniter Fixed Electrode Binding Post.....		1
	260 Igniter Fixed Electrode Steel Washer.....		1
	131 Igniter Fixed Electrode Nut.....		1

Repair Parts List—Fairbanks-Morse Type "Z" Gasoline Engine

13
2407C

Repair Numbers Arranged Numerically	The repair number in heavy type, when shown at the head of a group of parts, includes all items mentioned in that group.	Included in Group Number	No. Used
140	Igniter Slide Pin.....		1
141	Igniter Gasket.....		1
142	Magneto Gear.....	273-C	1
143	Igniter Trip Rod.....		1
144	Igniter Trip Rod Pin, in Gear.....	28-C	1
146	Cylinder Drain Plug.....	1-C	1
150	Connecting Rod Bolt, with Cotter only.....	18-C	2
151	Connecting Rod Bolt Castle Nut.....	18-C	2
160	Opposite Governor Bearing Thrust Washer.....		1
176	Connecting Rod Crank Pin Bushing (Halves).....	18-C	2
195	Name Plate.....	1-C	1
	Name Plate Brass Machine Screws.....	1-C	2
	Name Plate Rubber Washers.....	1-C	2
250	Cylinder to Igniter Stud.....	1-C	2
	Cylinder to Igniter Stud Nut.....		2
251	Fulcrum Pin Washer for either Governor Weight or Exhaust Rocker.....	32-C or 58-C	2
252	Crank Shaft Pinion Pin.....	13A	1
253	Fly-wheel Key.....		2
254	Governor Weight Fulcrum Pin, with Cotter.....	32-C	1
	Governor Weight Fulcrum Pin Nut.....	32-C	1
255	Governor Weight Eyebolt Eyescrew, in Fly-wheel Arm.....	32-C	1
256	Governor Weight Spring Eyebolt (thru 255), with Nuts.....	32-C	1
257	Igniter Fixed Electrode Mica Washers.....	138-C	2
258	Igniter Electrode Contact Point.....	138-C	2
259	Igniter Fixed Electrode Binding Post.....	138-C	1
260	Igniter Fixed Electrode Steel Washer.....	138-C	1
263	Suction Elbow Nozzle—not furnished separately.....	8-C	1
264	Fuel Tank Screw Cap.....	15	1
265	Starter Crank Pawl.....	14-C	1
266	Starter Crank Pawl Pin with Cotters.....	14-C	1
267	Starter Crank Pawl Spring.....	14-C	1
269	Silencer.....		1
271	Cylinder Oiler Pipe with Coupling.....		1
272	Pulley.....		1
	Pulley to Flywheel Machine Bolts.....		3
	273-C Special "Imp" Magneto.		
273-C			1
273	Special "Imp" Magneto with Key, Lock Washer and Nut.....		1
	Magneto to Base Cap Screws.....		2
	Magneto to Base Cap Screw Lock Washers.....		2
142	Magneto Gear.....		1
305	Igniter Movable Electrode Pawl Stop Pin.....	138-C	1
448	Suction Elbow Needle Valve Spring.....	8-C	1
476	Exhaust Valve Spring.....	10-C	1
505	Main Bearing Grease Cup.....		2
509	Connecting Rod Grease Cup.....		1
521	Detent Stop Pin.....	1-C	1
527	Cylinder Oiler.....		1
623	Igniter Movable Electrode to Body Wire Connector.....	138-C	1
	Igniter Movable Electrode Wire Connector Machine Screw.....	138-C	2
	Igniter Movable Electrode Wire Connector Machine Screw Lock Washer.....	138-C	2
634	Governor Weight Spring.....	32-C	1
646	Igniter Movable Electrode Pawl Spring.....	138-C	1
647	Detent Spring.....	42-C	1
656	Suction Valve Spring.....	8-C	1
	Complete Set of Springs for Engine.		1 set
267	Starter Crank Pawl Spring.....	14-C	1
448	Suction Elbow Needle Valve Spring.....	8-C	1
476	Exhaust Valve Spring.....	10-C	1
634	Governor Weight Spring.....	32-C	1
646	Igniter Movable Electrode Pawl Spring.....	138-C	1
647	Detent Spring.....	42-C	1
656	Suction Valve Spring.....	8-C	1
	8" Adjustable Wrench.....		1
	Zinc Hand Oiler.....		1
	Tin Funnel.....		1

TROUBLE CHART.

TROUBLE	POSSIBLE CAUSE	REMEDY	See Paragraph.	
Engine Will not Start.	Instructions not followed	Read and follow instructions	1 to 5	
	No gasoline in tank	Fill tank	1	
	Water in gasoline used in starting.	Strain gasoline	
	Water in combustion space	Water will work out if engine is turned over slowly	22	
	Engine flooded	See that Gasket is unbroken	
	Poor Compression	Exhaust valve leaks	Crank Engine	5
		Gasket leaks	Grind valve	21
		Piston blows	Put on new Gasket	22
	Engine very cold		Remove rings and clean	27-28
			Put but little water (preferably hot water) in hopper	2
Igniter short circuited		Take out Igniter, clean points	12	
		See that wire to Magneto is not grounded	16	
		Time of contact too short	Correct	10-11
			Correct	15
Engine Misses Fire after being Started	Short circuit	Correct	12 and 16	
	Loose wire	Tighten	16	
Engine Knocks	Hard explosion	Remove suction ell and clean carbon	22	
	Loose crank pin bearing	Take up bearing	
Engine Runs Irregularly	Governor stuck	See that governor parts are free. Use kerosene to loosen	
	Improper relation of Governor parts	See that detent and catch plate clearance is correct	23	
	WEAK exhaust valve spring	Put washer under spring till new spring can be obtained	

TROUBLE CHART.

TROUBLE	POSSIBLE CAUSE	REMEDY	See Paragraph
Engine Will not Carry Load	Exhaust valve setting.....	Reset.....	14
	Poor compression.....	See "Engine will not Start"	21-22-27-28
	Late Ignition.....	Correct.....	16
	Too Rich Mixture.....	Close Throttle.....	7
	Carbon in combustion space....	Remove head and clean....	
	Silencer clogged.....	Clean out.....	
Engine Uses too Much Fuel.	Throttle open too far.....	Close.....	7
	Poor compression.....	See "Engine will not Start"	23-24-27
	Late Ignition.....	Correct.....	11
	Exhaust valve setting.....	Reset.....	14
	Exhaust Pipe choked.....	Clean.....	
Water Boils Away Too Rapidly.	Mixture too rich.....	Close Throttle.....	6
	Late Ignition.....	Correct.....	11
		Never let water get below top of cylinder.....	

Fairbanks-Morse Type "Z" Gasoline Engines

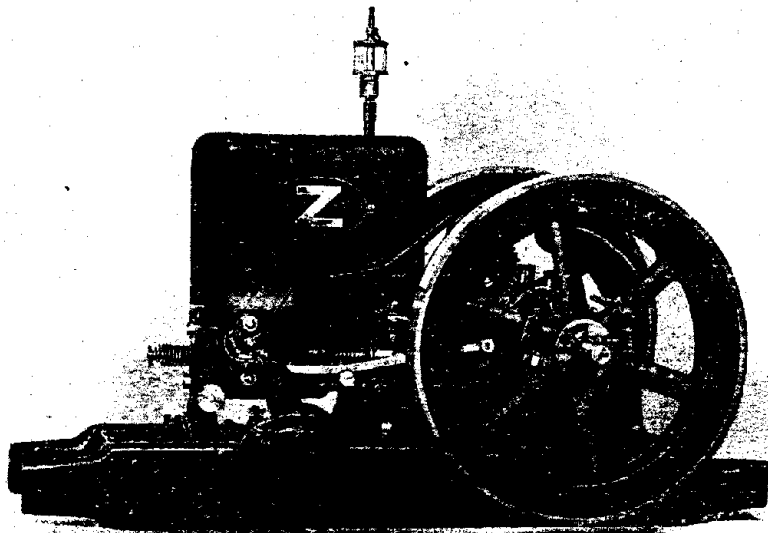

Fairbanks, Morse & Co.

(INCORPORATED)

Chicago, Ill.
St. Louis, Mo.
Cleveland, Ohio
Cincinnati, Ohio
Atlanta, Ga.
Jacksonville, Fla.
New Orleans, La.

New York, N. Y.
Boston, Mass.
Baltimore, Md.
Louisville, Ky.
Detroit, Mich.
Indianapolis, Ind.
Milwaukee, Wis.



St. Paul, Minn.
Minneapolis, Minn.
Kansas City, Mo.
Omaha, Neb.
Des Moines, Ia.
Denver, Colo.
Buenos Aires

San Francisco, Cal.
Los Angeles, Cal.
Spokane, Wash.
Seattle, Wash.
Portland, Oregon
Salt Lake City, Utah
London

The Canadian Fairbanks-Morse Co., Limited

Montreal Toronto Calgary Ottawa St. John, N. B. Winnipeg Saskatoon
Vancouver Hamilton Victoria Quebec Edmonton Regina